



Les machines industrielles Agro-Alimentaires

LOADING SYSTEM TYP V-K

for loading into tubular bag machines

Singer & Sohn GmbH

Singer & Sohn was founded in 1988 as a manufacturer of stainless steel conveyor systems and machines for the food industry.

A dynamic international family company, Singer is characterized by its value-oriented strategy for building business relationships and providing optimal service to its current customers.

From project planning and construction to manufacturing and programming through the mounting and commissioning – everything is delivered from one source. Our special representatives offer services worldwide to many companies and our in-house engineers are relied on by expert machine builders from many industries.

Meat, fish, sausage, cheese, bakery or sweets, Singer is right at home in each industry.

Our customized products and quality are well-known all over the world.

Manfred Singer

Industriepark Erasbach B1
D-92334 Berching
info@singer-und-sohn.de
www.singer-und-sohn.de





Les machines industrielles Agro-Alimentaires

1. Singularizing unit
2. Discharge conveyor
3. Portioning module
4. Touch panel



Technical data

Performance:
approx. 300 – 400 sausages / min (salami sticks)
Dimensions: 2930 x 2253 mm (L x H)
Height of product delivery: approx. 900 mm

Advantages

- ✓ optimal for depositing into horizontal tubular bag machines
- ✓ flexible
- ✓ short set-up times
- ✓ robust construction
- ✓ mobile stainless steel frame for easy connection to the packaging machine



Automatic loading of the tubular bag machine

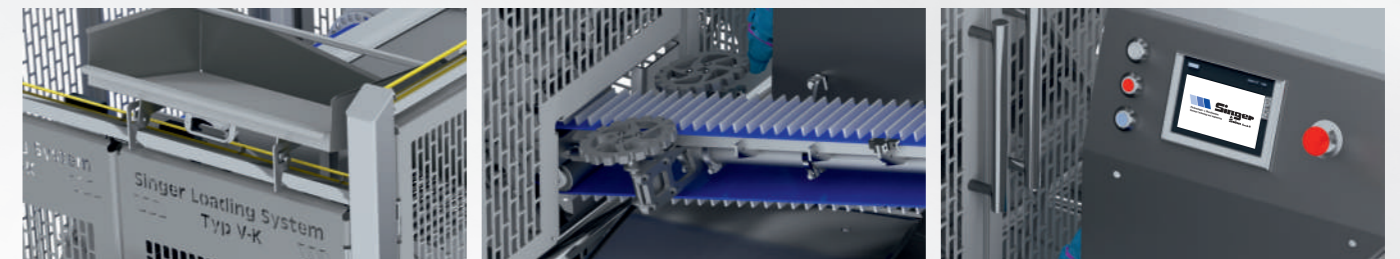

Reliable, efficient, flexible

The sausages are filled in large quantities into the bunker, singularized and orderly transported one by one out of the machine by a conveyor belt. In the next step, the products are counted in a 2-flap system and the desired quantity is loaded directly into the horizontal tubular bag machine. Built-in sensors provide a continuous filling process of the pre-set quantity.

The format and the number of products can be set individually in advance.

The complete loading system type V-K is equipped with a switch and control system that can easily be controlled via a user-friendly touch panel. Product changes or short-term changeovers can be carried out without any problems and the set-up and waiting times can be reduced enormously.

Interchangeable components make the system very flexible and easily adaptable to the different sausage and bag types.



The subject of Hygienic Design is on everyone's lips these days. Hygienic Design, applied correctly, is an essential part of ensuring hygienic food production. This is also our goal, so our designers are trained to design according to the applicable EHEDG regulations and the EN 1672-2 standard. This means that the systems from Singer & Sohn meet the highest requirements for hygiene and cleanability.

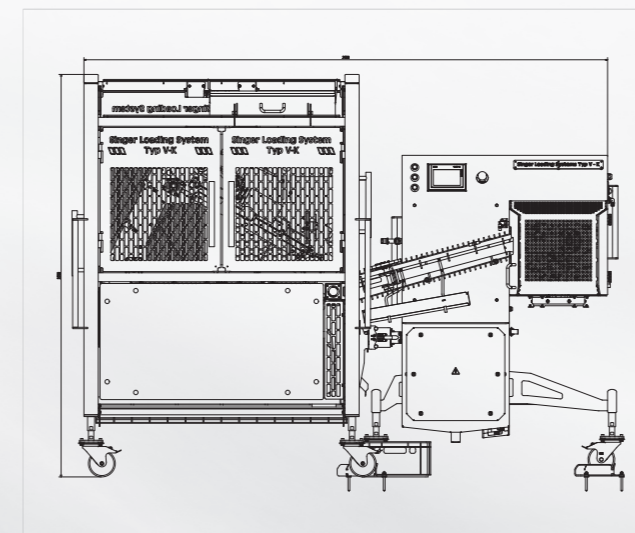



Feeding

The feeding unit is equipped with a bunker including a dosing conveyor belt for the infeed of the product. Thus, big amounts can be passed through. With the assistance of the climbing belt, the product gets into the singularizing unit.

The feeding of the product can be done variably:

- > Feeding via smoke sticks
- > Feeding via conveyors with buffer



Singularizing

In the singularizing unit, a sorting conveyor belt with paddle is located. The products are separated and placed on a conveyor belt.



Grouping

The product reaches the grouping module on a conveyor belt. Here, it is grouped, by given quantities. The groups can be defined in the system through various product formulations.

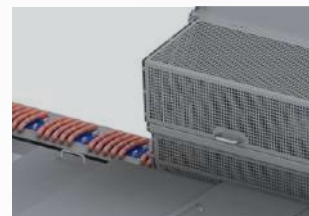

Aligning (optional)

In the aligning unit curved products are aligned in one direction and subsequently supplied via a further conveyor belt to the delta robot system.



Rotating (optional)

The product can also be turned, depending on the loading patterns either crosswise or lengthwise to the packaging machine. This can be achieved with the rotary axis, in the delta robot system.



Depositing

The pre-grouped products are brought into the delta robot system and picked by the gripper which loads the product into the packaging. If the packaging is very tight the product can be loaded by the assistance of a pusher.

