

BELT MACHINES

GK 600 / 610 B SERIES





Your benefits

- 1 Rugged stainless steel construction for maximum durability.
- 2 Double biactive sealing bars for firm and reliable seals.
- 3 Expansion cushion in the vacuum chamber for an optimized evacuation process.
- 4 Various options available for a perfect cut of protruding bag material.
- 5 Several sealing bar heights to adjust to the product.
- 6 Touch screen for simple and clear operation.
- 7 Various heights in the vacuum chamber for optimal adjustment to the product.
- 8 Use of tried-and-tested electronics and pneumatics components.
- 9 Optimized BUSCH vacuum pump combinations to choose from.
- 10 Hygienic design – easy to clean.
- 11 Control box heating.

Touch screen

- ◆ Simple and easy touch-screen operation.
- ◆ Electronic monitoring of the work process and displays in comprehensible and well-arranged on-screen menus.
- ◆ 20 programs activated.
- ◆ Programs can be locked by password.
- ◆ Alphanumeric display for individual program naming, e.g. product name, bag material, etc.
- ◆ Integrated high-precision digital vacuum meter.
- ◆ Chamber vacuum displayed in mbar.
- ◆ Evacuation, optionally:
 - ◆ Optimum – up to the evaporation point.
 - ◆ Evacuation time given in tenths of a second.
 - ◆ Final vacuum given in mbar.
 - ◆ in intervals.
- ◆ Sealing time in tenths of a second.
- ◆ Cooling time in tenths of a second.
- ◆ Waterproof according to IP65F.

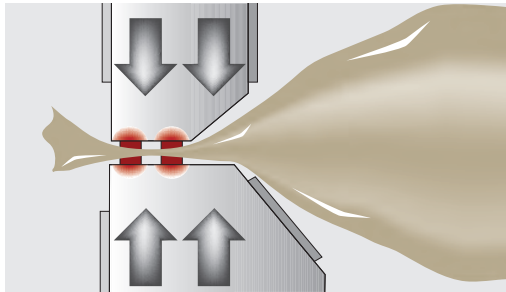

The **double biactive high-pressure sealing** and the **spring-loaded resistance wires** are standard equipment and ensure safe and reliable seals despite folds, fats, oils or moisture in the seal area. Springs keep the resistance wires in the correct track even with continuous operation.



Height-adjustable sealing bars
Perfect look and flexibility through adjustment to different product heights.

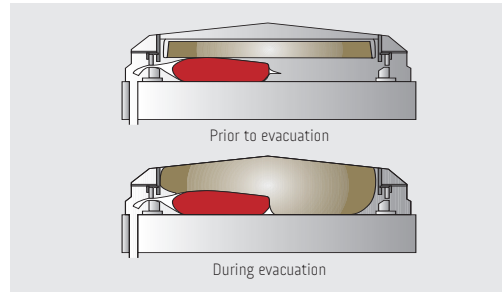

The **expansion cushion with removable frame** reduces the evacuation time by up to 30% and prevents folds on the top side of the package.

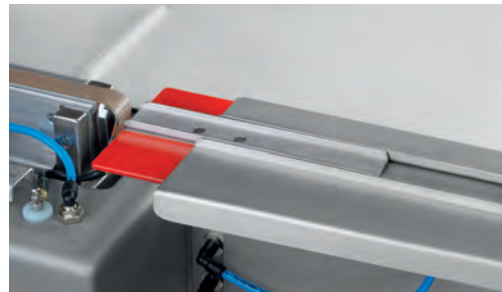

Water-cooled sealing bars increase the durability of the Teflon and the sealing wires.



Cut-off device
By means of rotary blades, protruding bag material is cut off in front of the chamber.

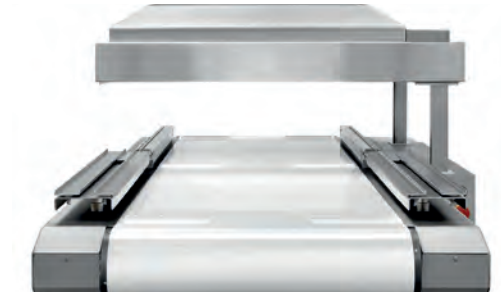

Various **lid heights**:
GK 602B – with a lid height of 200 mm.
GK 603B – with a lid height of 300 mm.
GK 612B – including loading belt (1 operator) – lid height of 200 mm.
GK 613B – including loading belt (1 operator) – lid height of 300 mm.

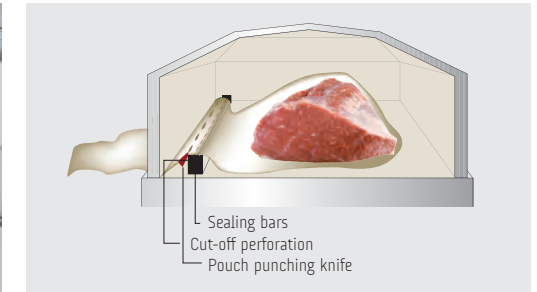

The **cut-off perforation** allows the manual removal of the protruding bag material.

The **pouch punching knives** are necessary so that the package can be evacuated even if the bag opening protrudes from the chamber.



A **indexing loading belt** supports ergonomic and swift loading of the machine and is a prerequisite for later automation of the loading area.

Standard equipment

- ◆ Touch screen control.
- ◆ Double biactive high-pressure sealing.
- ◆ Expansion cushion with removable frame.
- ◆ Shrink bag equipment
- ◆ Quick easing of tension of the conveyor belt for easy cleaning.
- ◆ Gentle start and stop of the conveyor belt.
- ◆ Temperature-controlled control box heating.

Options

- ◆ Height-adjustable sealing bars (GK 602B / GK 603B) – can be set to touch screen control.
- ◆ Loading belt – 1 operator (GK 612B / GK 613B).
- ◆ Cut-off device.
- ◆ Pouch punching knife.
- ◆ Cut-off perforation.
- ◆ Shrink bag equipment.
- ◆ Water-cooled sealing bars.
- ◆ Conveyor belt with cross profiles for round products (GK 602B / GK 603B).
- ◆ Outfeed rollers 250 mm or 500 mm.
- ◆ Booster and rotary van pump combinations.



*Constructed of corrosion-resistant stainless steel.
Easy-to-clean, hygiene-friendly machine design.*

GK 600 / 610 B SERIES



Technical data

Chamber size		1120 x 1100 mm
Lid height	GK 602B / GK 612B	200 mm
	GK 603B / GK 613B	300 mm
Sealing length		2 x 1000 mm
Spacing between bars		830 mm
Fixed sealing bar height		15, 35, 55 oder 75 mm
Other sealing heights		on request
Height-adjustable sealing bars (GK 602B / GK 603B)		15 - 80 mm
Compressed air consumption		80 NLPM 6 bar
Power supply (without vacuum pump) approx.		3.8 kW
Built-in vacuum pump, frequency-controlled		1000 or 1250 m ³ /h
External vacuum pump		2 x 250 or 630 m ³ /h
Other pump systems		on request
Total weight without pump		approx. 1000 kg

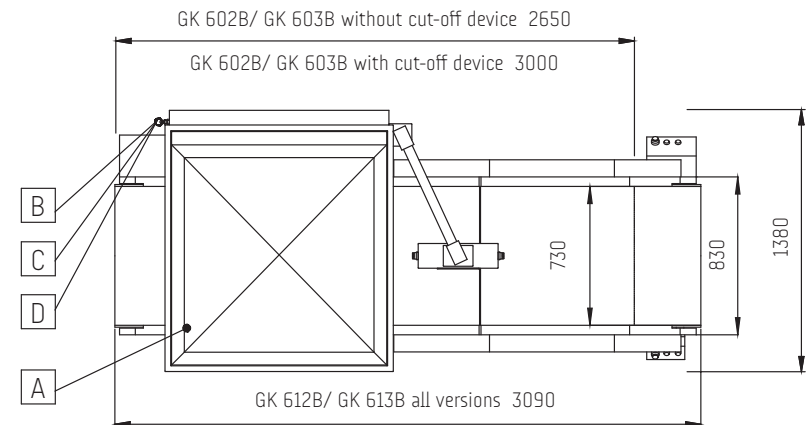
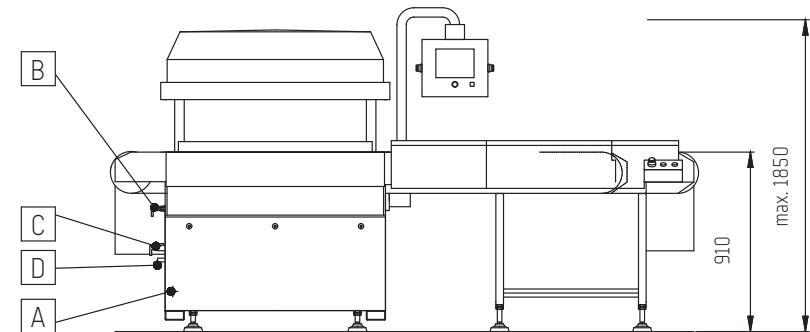

A Power supply **B** Compressed air connection **C** Water supply **D** Water drain



supervac 
FIRST CLASS PERFORMANCE

Supervac Maschinenbau GmbH
Kalterer Gasse 10
2340 Mödling | Austria

T: +43 2236 50 25 00

E-mail: office@supervac.at
Web: www.supervac.at